

## YQ21H-8501M

### Features

- ✓ Supports 103.1Gbps aggregate bit rates
- ✓ 4x25.78Gbps 850nm VCSEL transmitter and PIN receiver
- ✓ Maximum link length of 70m on OM3 MMF and 100m on OM4 MMF
- ✓ Single MPO receptacle
- ✓ Hot pluggable QSFP28 form factor
- ✓ Power dissipation < 2.5W
- ✓ All-metal housing for superior EMI performance
- ✓ RoHS6 compliant (lead free)
- ✓ Operating case temperature:  
Commercial: 0°C to +70°C



### Applications

- ✓ 100GBASE-SR4
- ✓ InfiniBand FDR/EDR

### Standards

- ✓ Compliant with QSFP28 MSA
- ✓ Compliant with SFF-8636
- ✓ Compatible with IEEE802.3bm

### Description

The QSFP28 transceivers are designed for use in 100-Gigabit Ethernet links up to 100m over Multimode Mode Fiber.

The transceivers are compatible with QSFP28 MSA and SFF-8636. For further information, please refer to QSFP28 MSA and SFF-8636.

## Module Block Diagram

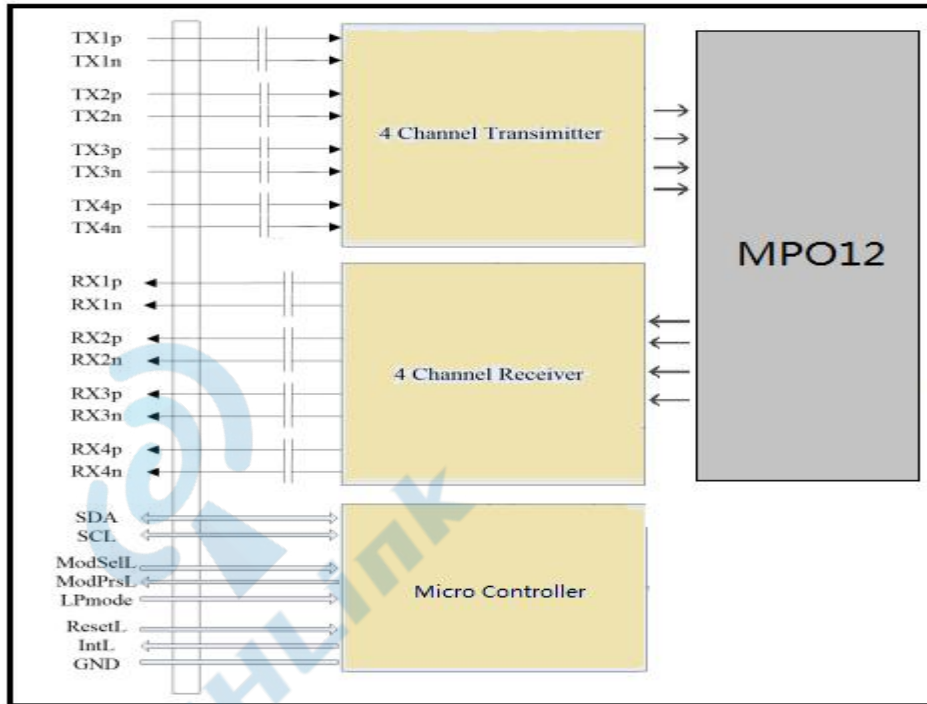

## Absolute Maximum Ratings

Parameter	Symbol	Min.	Typical	Max.	Unit
Power Supply Voltage	V <sub>CC</sub>	0		3.6	V
Storage Temperature	T <sub>s</sub>	-40		+85	°C
Relative Humidity	RH	0		85	%
RX Input Average Power per Lane	P <sub>max</sub>	-		3.5	dBm

## Recommended Operating Environment

Parameter	Symbol	Min.	Typical	Max.	Unit
Power Supply Voltage	V <sub>CC</sub>	3.13	3.3	3.46	V
Power Supply Current	I <sub>CC</sub>			750	mA
Power Dissipation	P <sub>D</sub>			2.5	W
Operating Case Temperature	T <sub>C</sub>	0		+70	°C
Aggregate Data Rate	-		103.125		Gbps
Bit Rate per Lane	BR		25.78125		Gbps

## Electrical Characteristics

Parameter	Symbol	Min.	Typical	Max.	Unit	Note
<b>Transmitter Section</b>						
Input Differential Impedance	$R_{in}$	90	100	110	$\Omega$	
Differential Data Input Swing	$V_{in\ PP}$	180		1000	mV	1
<b>Receiver Section</b>						
Differential Data Output Swing	$V_{out\ PP}$	300		850	mV	

### Notes:

1. Connected directly to TX data input pins. AC coupling from pins into laser driver IC.

## Optical Parameters

Parameter	Symbol	Min.	Typical	Max.	Unit	Note
<b>Transmitter Section</b>						
Lane Centre Wavelength (range)	$\lambda_c$	840		860	nm	
Spectral Width (RMS)	$\sigma$			0.6	nm	
Average Optical Power per Lane	$P_{out}$	-8.4		+2.4	dBm	1
OMA Power per Lane	OMA	-6.4		3	dBm	1
Laser Off Power per Lane	$P_{off}$	-	-	-30	dBm	
Extinction Ratio	ER	3	-	-	dB	2
Relative Intensity Noise	RIN	-	-	-128	dB/Hz	
Optical Return Loss Tolerance		-	-	12	dB	
Transmitter eye mask definition {X1, X2, X3, Y1, Y2, Y3}		Compliant with IEEE802.3bm {0.3, 0.38, 0.45, 0.35, 0.41, 0.5}				2
<b>Receiver Section</b>						
Lane Center Wavelength (range)	$\lambda_c$	840		860	nm	
Average Receiver Power per Lane	$RXP_X$	-10.3		2.4	dBm	3
OMA Stressed Sensitivity per Lane	$RX_{sens}$			-5.2	dBm	3
Los Assert	$LOS_A$	-30	-	-	dBm	
Los Dessert	$LOS_D$	-	-	-13	dBm	
Los Hysteresis	$LOS_H$	0.5	-	5	dB	
Overload per Lane	$P_{in-max}$	-	-	2.4	dBm	3
Receiver Reflectance		-	-	-12	dB	
Damage Threshold per Lane		-	-	3.5	dBm	

### Notes:

1. The optical power is launched into 50/125 $\mu$ m MMF.
2. Measured with a PRBS  $2^{31}-1$  test pattern @25.78Gbps.
3. Measured with a PRBS  $2^{31}-1$  test pattern @25.78Gbps, ER=3dB, BER <  $10^{-12}$ .

## Pin Definitions

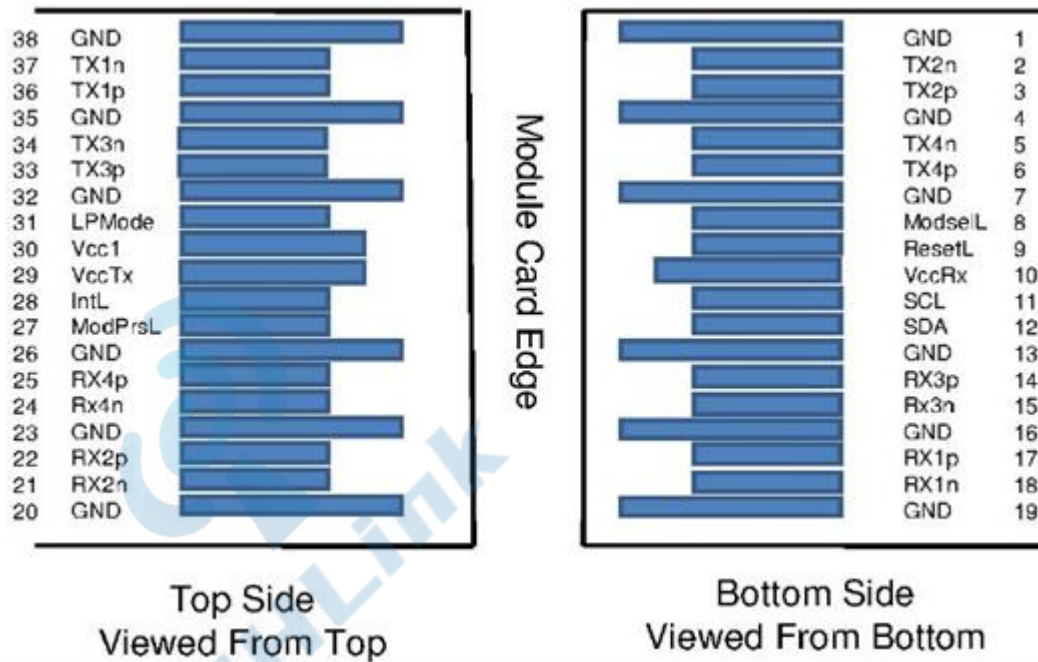

## Pin Descriptions

Pin	Symbol	Description	Plug Seq.	Notes
1	Ground	Ground	1	1
2	Tx2n	Transmitter Inverted Data Input	3	
3	Tx2p	Transmitter Non-Inverted Data Input	3	
4	Ground	Ground	1	1
5	Tx4n	Transmitter Inverted Data Input	3	
6	Tx4p	Transmitter Non-Inverted Data Input	3	
7	Ground	Ground	1	1
8	ModSelL	Module Select	3	
9	ResetL	Module Reset	3	
10	VccRx	+3.3 V Power supply receiver	2	2
11	SCL	2-wire serial interface clock	3	
12	SDA	2-wire serial interface data	3	
13	Ground	Ground	1	1
14	Rx3p	Transmitter Non-Inverted Data Input	3	
15	Rx3n	Transmitter Inverted Data Input	3	
16	Ground	Ground	1	1
17	Rx1p	Transmitter Non-Inverted Data Input	3	
18	Rx1n	Transmitter Inverted Data Input	3	
19	Ground	Ground	1	1
20	Ground	Ground	1	1

21	Rx2n	Transmitter Inverted Data Input	3	
22	Rx2p	Transmitter Non-Inverted Data Input	3	
23	Ground	Ground	1	1
24	Rx4n	Transmitter Inverted Data Input	3	
25	Rx4p	Transmitter Non-Inverted Data Input	3	
26	Ground	Ground	1	1
27	ModPrsL	Module Present	3	
28	IntL	Interrupt	3	
29	VccTx	+3.3 V Power supply transmitter	2	2
30	Vcc1	+3.3 V Power Supply	2	2
31	LPMODE	Low Power Mode	3	
32	Ground	Ground	1	1
33	Tx3p	Transmitter Non-Inverted Data Input	3	
34	Tx3n	Transmitter Inverted Data Input	3	
35	Ground	Ground	1	1
36	Tx1p	Transmitter Non-Inverted Data Input	3	
37	Tx1n	Transmitter Inverted Data Input	3	
38	Ground	Ground	1	1

**Notes:**

Plug Seq.: Pin engagement sequence during hot plugging.

1. Module ground pins GND are isolated from the module case.
2. VccRx, Vcc1 and VccTx are the receiver and transmitter power supplies and shall be applied concurrently.

**Recommended Power Interface Circuit**

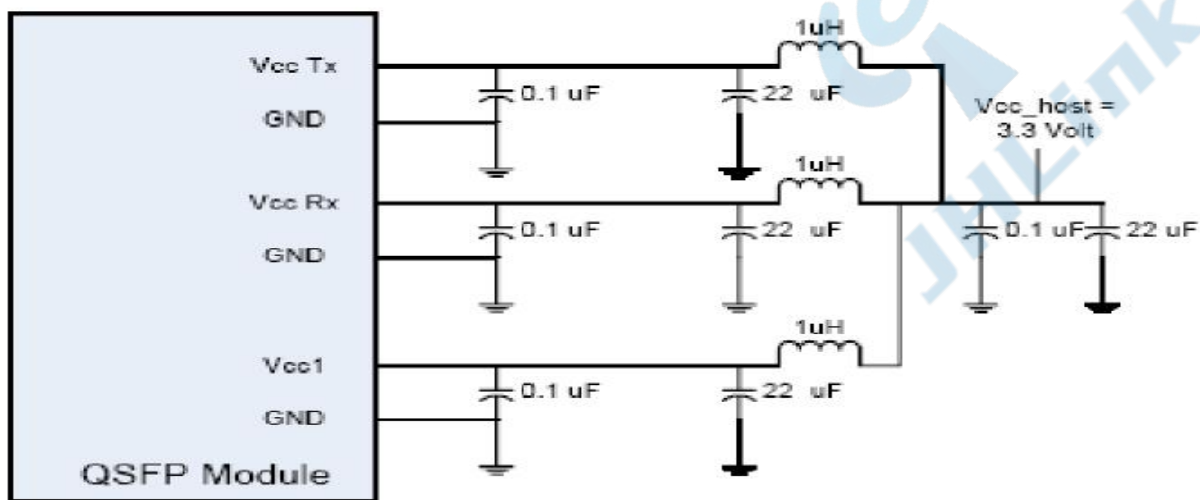

**Recommended Interface Circuit**

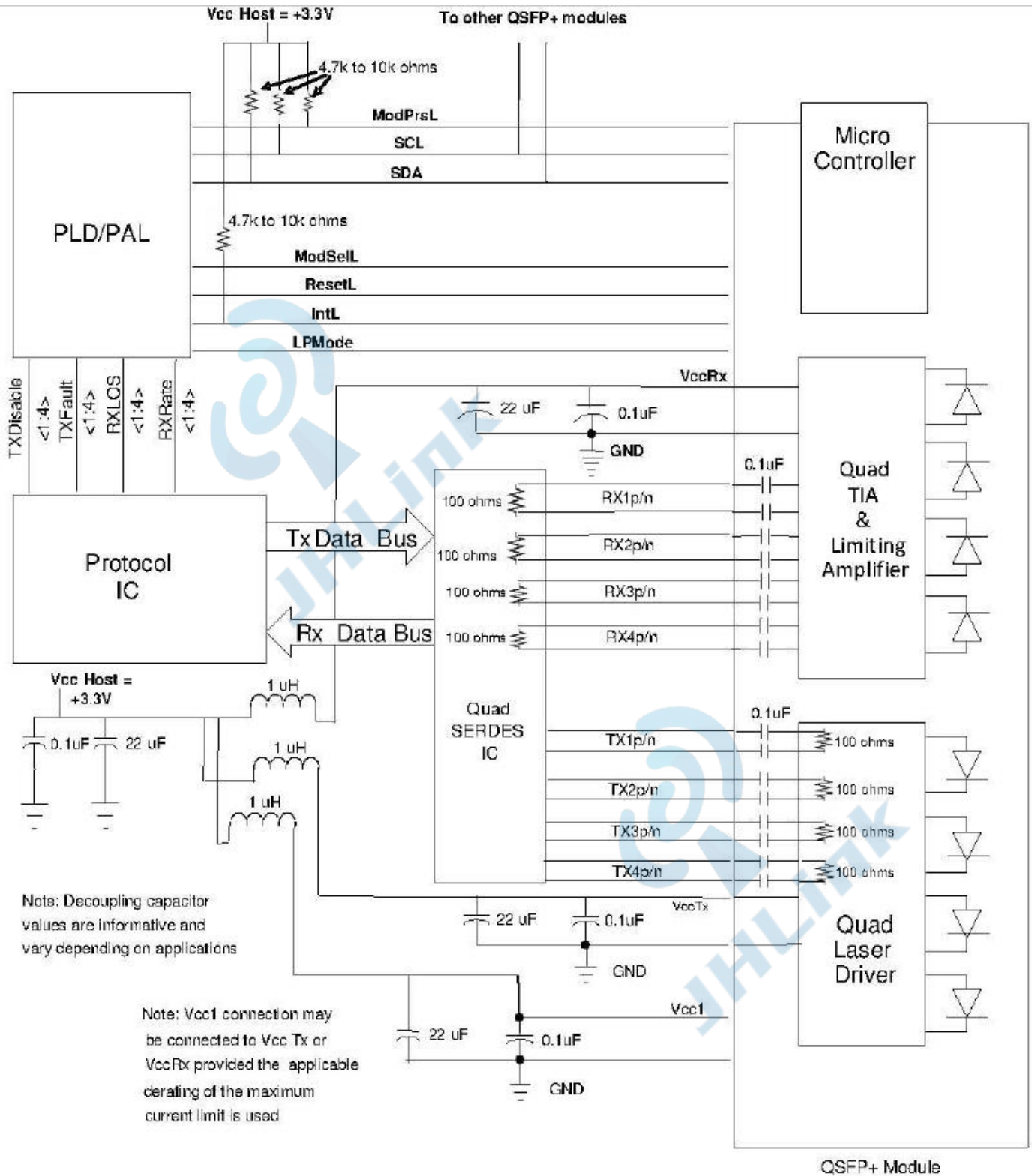

## Digital Diagnostic Functions

The QSFP28 transceivers support the 2-wire serial communication protocol as defined in the QSFP28 MSA, which allows real-time access to the following operating parameters:

- ✓ Transceiver temperature
- ✓ Laser bias current
- ✓ Transmitted optical power
- ✓ Received optical power
- ✓ Transceiver supply voltage

It also provides a sophisticated system of alarm and warning flags, which may be used to alert end-users when particular operating parameters are outside of a factory-set normal range.

The operating and diagnostics information is monitored and reported by a Digital Diagnostics Transceiver Controller inside the transceiver, which is accessed through the 2-wire serial interface. When the serial protocol is activated, the serial clock signal (SCL pin) is generated by the host. The positive edge clocks data into the QSFP28 transceiver into those segments of its memory map that are not write-protected. The negative edge clocks data from the QSFP28 transceiver. The serial data signal (SDA pin) is bi-directional for serial data transfer. The host uses SDA in conjunction with SCL to mark the start and end of serial protocol activation. The memories are organized as a series of 8-bit data words that can be addressed individually or sequentially. The 2-wire serial interface provides sequential or random access to the 8 bit parameters, addressed from 00h to the maximum address of the memory.

This clause defines the Memory Map for QSFP28 transceiver used for serial ID, digital monitoring and certain control functions. The interface is mandatory for all QSFP28 devices. The memory map has been changed in order to accommodate 4 optical channels and limit the required memory space. The structure of the memory is shown in Figure 2 QSFP28 Memory Map. The memory space is arranged into a lower, single page, address space of 128 bytes and multiple upper address space pages. This structure permits timely access to addresses in the lower page, e.g. Interrupt Flags and Monitors. Less time critical entries, e.g. serial ID information and threshold settings, are available with the Page Select function. The structure also provides address expansion by adding additional upper pages as needed. For example, in Figure 2 upper pages 01 and 02 are optional. Upper page 01 allows implementation of Application Select Table, and upper page 02 provides user read/write space. The lower page and upper pages 00 and 03 are always implemented. The interface address used is A0 and is mainly used for time critical data like interrupt handling in order to enable a “one-time-read” for all data related to an interrupt situation. After an Interrupt, IntL, has been asserted, the host can read out the flag field to determine the effected channel and type of flag.

For more detailed information including memory map definitions, please see the QSFP28 MSA Specification.

## Mechanical Dimensions

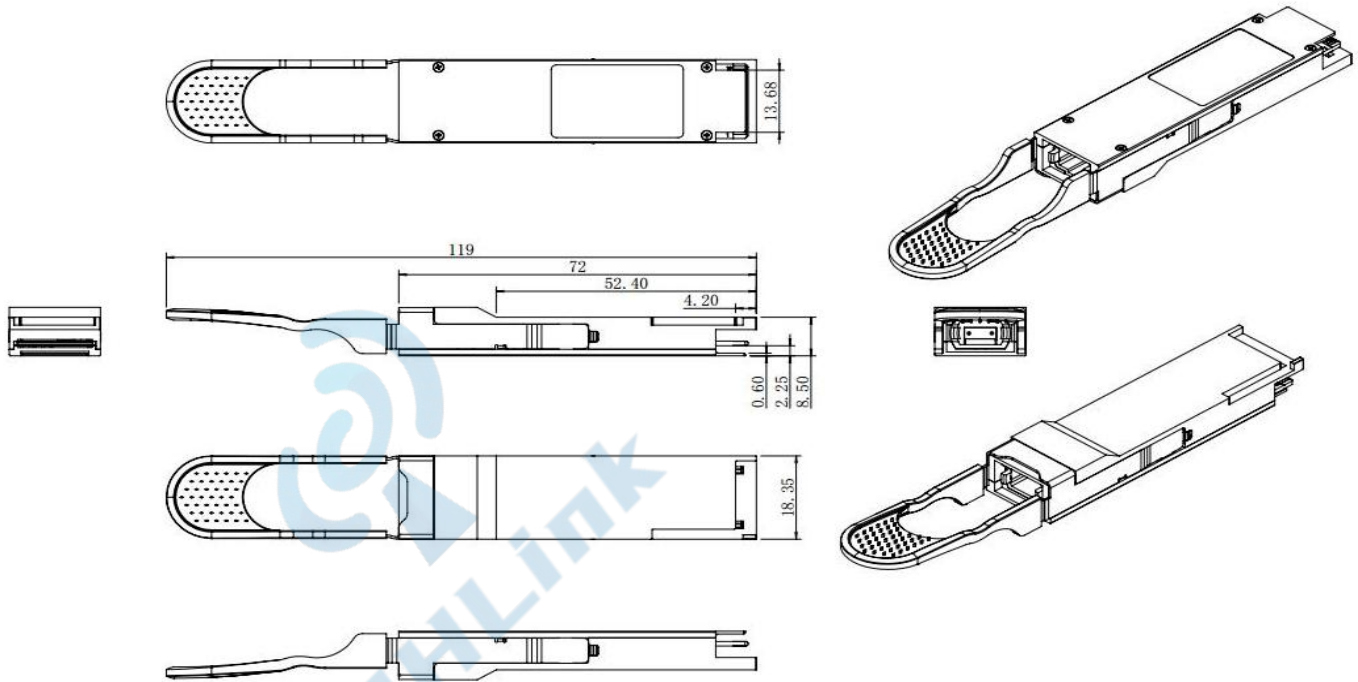

## Ordering information

Part Number	Product Description
YQ21H-8501M	100Gbps QSFP28 SR4, 100m on MMF(OM4), MPO receptacle, 0°C ~ +70°C, With DDM.

## References

1. SFF-8679 Specification for QSFP+ 4X Hardware and Electrical Specification.
2. SFF-8636 Specification for Management Interface for Cabled Environments.
3. IEEE 802.3bm - PMD Type 100GBASE-SR4.

## Important Notice

Performance figures, data, and any illustrative material provided in this datasheet are typical and must be specifically confirmed in writing by JHLINK before they become applicable to any particular order or contract. In accordance with the JHLINK policy of continuous improvement, specifications may change without notice. The publication of information in this datasheet does not imply freedom from patent or other protective rights of JHLINK or others. Further details are available from any JHLINK sales representative.

## Contact Information

SHENZHEN JUHAIDA INDUSTRIAL DEPLOYMENT CO., LTD.  
 ADD:HAIHONG INDUSTRIAL PARK,XIXIANGSTREET, BAO'ANDISTRICT,SHENZHEN,CHINA EMAIL:  
 rainyu77777@gmail.com  
 WhatsApp:+86 18805172117