

YSP24-B4580&YSP24-B5480

Features

- ✓ Up to 2.5Gbps data links
- ✓ 1490nm DFB laser transmitter and PIN photo-detector for YSP24-B4580
- ✓ 1550nm DFB laser transmitter and PIN photo-detector for YSP24-B5480
- ✓ Up to 80km on 9/125μm SMF
- ✓ Simplex LC receptacle optical interface compliant
- ✓ Hot pluggable
- ✓ All-metal housing for superior EMI performance
- ✓ RoHS6 compliant (lead free)
- ✓ Operating case temperature:
Commercial: -5°C to +70°C
Extended: -20°C to +80°C
Industrial: -40°C to +85°C



Applications

- ✓ SONET OC-48/ SDH STM-16
- ✓ Fiber Channel
- ✓ Switch to Switch interface
- ✓ Switched backplane applications
- ✓ Router/Server interface
- ✓ Other optical transmission systems

Standards

- ✓ Compliant with SFP MSA
- ✓ Compliant with SFF-8472
- ✓ Compliant with SONET OC-48/ SDH STM-16

Description

The SFP transceivers are high performance, cost effective modules supporting data-rate of 2.5Gbps and 80km transmission distance with SMF.

The transceivers are compatible with SFP Multi-Source Agreement (MSA) and SFF-8472. For further information, please refer to SFP MSA and SFF-8472.

Module Block Diagram

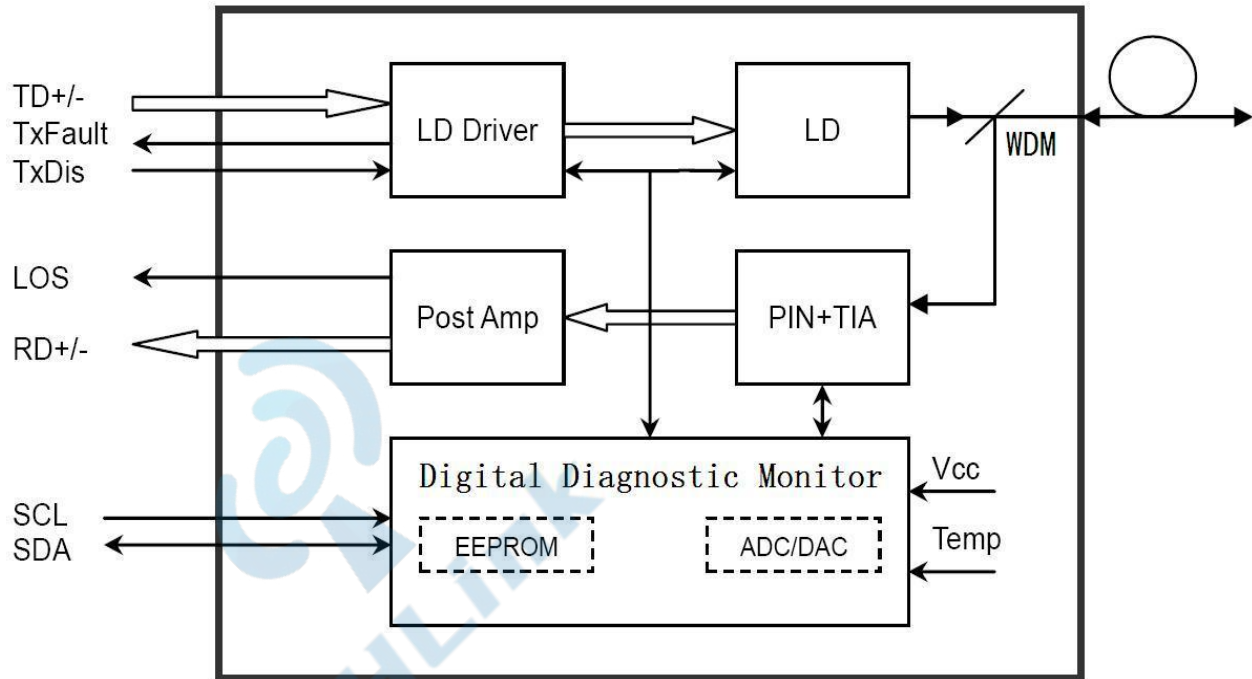

Absolute Maximum Ratings

Parameter	Symbol	Min.	Typical	Max.	Unit
Power Supply Voltage	V _{CC}	0		3.6	V
Storage Temperature	T _s	-40		+85	°C
Operating Case Temperature	T _c	-40		+85	°C
Relative Humidity	RH	0		85	%
RX Input Average Power	P _{max}	-		3	dBm

Recommended Operating Environment

Parameter	Symbol	Min.	Typical	Max.	Unit
Power Supply Voltage	V _{CC}	3.13	3.3	3.46	V
Power Supply Current	I _{CC}			300	mA
Operating Case Temperature	Commercial	-5		+70	°C
	Extended	-20		+80	
	Industrial	-40		+85	
Data Rate			2.125/2.5		Gbps

Electrical Characteristics

Parameter	Symbol	Min.	Typical	Max.	Unit	Note
Transmitter Section						
Input Differential Impedance	R_{in}	90	100	110	Ω	
Single Ended Data Input Swing	$V_{in\ PP}$	250		1000	mV	1
Transmit Disable Voltage	V_D	$V_{cc} - 1.3$		V_{cc}	V	
Transmit Enable Voltage	V_{EN}	V_{ee}		$V_{ee} + 0.8$	V	
Receiver Section						
Single Ended Data Output Swing	$V_{out\ PP}$	300		600	mV	
LOS Fault	$V_{los\ fault}$	$V_{cc} - 0.5$		V_{cc_host}	V	2
LOS Normal	$V_{los\ norm}$	V_{ee}		$V_{ee} + 0.5$	V	2

Notes:

1. Connected directly to TX data input pins. AC coupling from pins into laser driver IC.
2. LOS is an open collector output. Should be pulled up with 4.7k Ω – 10k Ω on the host board. Normal operation is logic 0; loss of signal is logic 1.

Optical Parameters

Parameter	Symbol	Min.	Typical	Max.	Unit	Note
Transmitter Section						
Centre Wavelength	λ_c	1470	1490	1510	nm	YSP24-B4580
		1530	1550	1570	nm	YSP24-B5480
Spectral Width (-20dB)	$\Delta\lambda$			1	nm	
Side Mode Suppression Ratio	SMSR	30			dB	
Average Optical Power (avg.)	P_{out}	0		+5	dBm	1
Laser Off Power	P_{off}	-	-	-45	dBm	
Extinction Ratio	ER	8.2	-	-	dB	2
Relative Intensity Noise	RIN	-	-	-128	dB/Hz	
Optical Rise/Fall Time	t_r / t_f		-	160	ps	3
Optical Return Loss Tolerance		-	-	12	dB	
Output Optical Eye	Compliant with ITU-T G.957					2
Receiver Section						
Receiver Center Wavelength	λ_c	1530	1550	1570	nm	YSP24-B4580
		1470	1490	1510	nm	YSP24-B5480
Receiver Sensitivity in Average Power	Sen	-26		0	dBm	4
Los Assert	LOS_A	-35	-	-	dBm	
Los Dessert	LOS_D	-	-	-28	dBm	
Los Hysteresis	LOS_H	0.5	-	5	dB	
Overload	P_{in-max}	-	-	0	dBm	4
Receiver Reflectance		-	-	-12	dB	
Receiver Power (damage)		-	-	3	dBm	

Notes:

1. The optical power is launched into 9/125µm SMF.
2. Measured with a PRBS 2^{23} -1 test pattern @2.5Gbps.
3. Unfiltered, 20-80%. Measured with a PRBS 2^{23} -1 test pattern @2.5Gbps.
4. Measured with a PRBS 2^{23} -1 test pattern @2.5Gbps, ER=9dB, BER < 10^{-12} .

Timing Characteristics

Parameter	Symbol	Min.	Typical	Max.	Unit
TX_Disable Assert Time	t_off			10	us
TX_Disable Negate Time	t_on			1	ms
Time to Initialize Include Reset of TX_FAULT	t_init			300	ms
TX_FAULT from Fault to Assertion	t_fault			100	us
TX_Disable Time to Start Reset	t_reset	10			us
Receiver Loss of Signal Assert Time	T _A , RX_LOS			100	us
Receiver Loss of Signal Deassert Time	T _d , RX_LOS			100	us
Rate-Select Change Time	t_ratesel			10	us
Serial ID Clock Time	f_serial-clock			100	kHz

Digital Diagnostic Monitor Characteristics (DDM)

The following digital diagnostic characteristics are defined over the Recommended Operating Environment unless otherwise specified. It is compliant to SFF8472 Rev10.2 with internal calibration mode. For external calibration mode please contact our sales staff.

Parameter	Symbol	Min.	Max.	Unit
Temperature Monitor Absolute Error	DMI_Temp	-3	3	°C
Laser Power Monitor Absolute Error	DMI_TX	-3	3	dB
RX Power Monitor Absolute Error	DMI_RX	-3	3	dB
Supply Voltage Monitor Absolute Error	DMI_VCC	-3%	3%	V
Bias Current Monitor Absolute Error	DMI_Ibias	-10%	10%	mA

Digital Diagnostic Memory Map (Compliant with SFF-8472)

The transceivers provide serial ID memory contents and diagnostic information about the present operating conditions by the 2-wire serial interface (SCL, SDA).

The diagnostic information with internal calibration or external calibration all are implemented, including received power monitoring, transmitted power monitoring, bias current monitoring, supply voltage monitoring and temperature monitoring.

The digital diagnostic memory map specific data field defines as following (For further information, please refer to SFF-8472).

Pin Descriptions

Pin	Signal Name	Description	Plug Seq.	Notes
1	VeeT	Transmitter Ground	1	
2	TX FAULT	Transmitter Fault Indication	3	1
3	TX Disable	Transmitter Disable	3	2
4	MOD_DEF(2)	I^2C Serial Data Signal SDA	3	3
5	MOD_DEF(1)	I^2C Serial Clock Signal SCL	3	3
6	MOD_DEF(0)	Grounded in Module	3	3
7	Rate Select	Not Connected	3	
8	LOS	Receiver Loss of Signal Indicator (Active high, open-drain)	3	4
9	VeeR	Receiver Ground	1	
10	VeeR	Receiver Ground	1	
11	VeeR	Receiver Ground	1	
12	RD-	Inv. Received Data Out	3	5
13	RD+	Received Data Out	3	5
14	VeeR	Receiver Ground	1	
15	VccR	Receiver Power Supply	2	
16	VccT	Transmitter Power Supply	2	
17	VeeT	Transmitter Ground	1	
18	TD+	Transmit Data In	3	6
19	TD-	Inv. Transmit Data In	3	6
20	VeeT	Transmitter Ground	1	2

Notes:

Plug Seq.: Pin engagement sequence during hot plugging.

1. TX Fault is an open collector output, which should be pulled up with a 4.7k~10kΩ resistor on the host board to a voltage between 2.0V and Vcc+0.3V. Logic 0 indicates normal operation; Logic 1 indicates a laser fault of some kind. In the low state, the output will be pulled to less than 0.8V.

2. TX Disable is an input that is used to shut down the transmitter optical output. It is pulled up within the module with a 4.7k~10kΩ resistor. Its states are:

Low (0 to 0.8V): Transmitter on;

Between (>0.8V, < 2.0V): Undefined;

High (2.0 to 3.465V): Transmitter Disabled;

Open: Transmitter Disabled.

3. Mod-Def0, 1, 2: These are the module definition pins. They should be pulled up with a 4.7k~10kΩ resistor on the host board. The pull-up voltage shall be VccT or VccR.

MOD_DEF (0) is grounded by the module to indicate that the module is present.

MOD_DEF (1) is the clock line of two wire serial interface for serial ID SCL.

MOD_DEF (2) is the data line of two wire serial interface for serial ID SDA.

4. LOS is an open collector output, which should be pulled up with a 4.7k~10kΩ resistor. Pull up voltage between 2.0V and Vcc+0.3V. Logic 1 indicates loss of signal; Logic 0 indicates normal operation. In the low state, the output will be pulled to less than 0.8V.

5. RD-/+ : These are the differential receiver outputs. They are internally AC-coupled 100 differential lines which should be terminated with 100Ω (differential) at the user SERDES.

6. TD-/+ : These are the differential transmitter inputs. They are internally AC-coupled, differential lines with 100Ω differential termination inside the module.

Recommended Interface Circuit

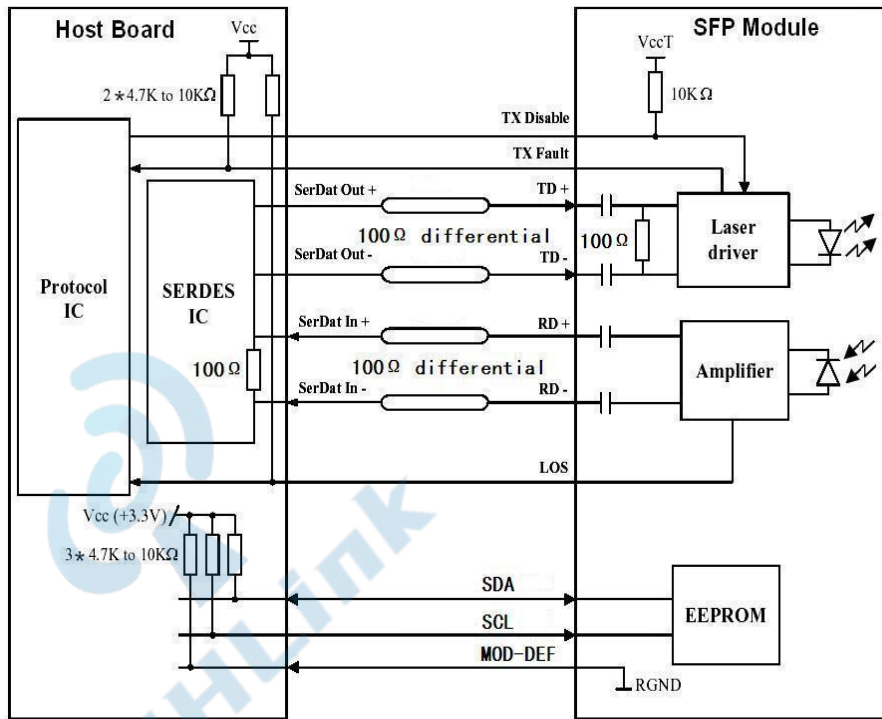

Mechanical Dimensions

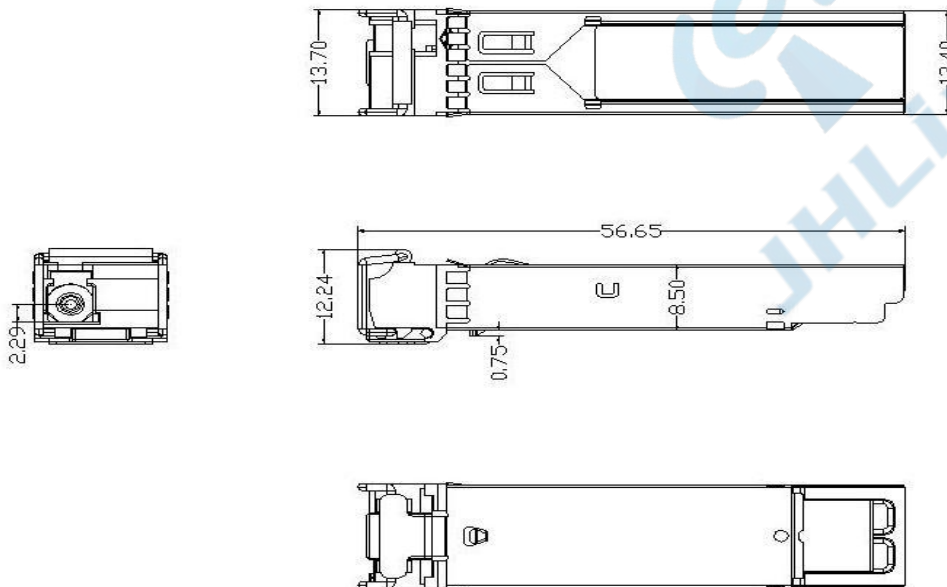

Ordering information

Part Number	Product Description
YSP24-B4580	Tx1490nm, Rx1550nm, 2.5Gbps, 80km, Bi-Directional SFP Transceiver with Single LC Receptacle, -5°C ~ +70°C, With DDM.
YSP24-B4580E	Tx1490nm, Rx1550nm, 2.5Gbps, 80km, Bi-Directional SFP Transceiver with Single LC Receptacle, -20°C ~ +80°C, With DDM.
YSP24-B4580T	Tx1490nm, Rx1550nm, 2.5Gbps, 40km, Bi-Directional SFP Transceiver with Single LC Receptacle, -40°C ~ +85°C, With DDM.
YSP24-B5480	Tx1550nm, Rx1490nm, 2.5Gbps, 80km, Bi-Directional SFP Transceiver with Single LC Receptacle, -5°C ~ +70°C, With DDM.
YSP24-B5480E	Tx1550nm, Rx1490nm, 2.5Gbps, 80km, Bi-Directional SFP Transceiver with Single LC Receptacle, -20°C ~ +80°C, With DDM.
YSP24-B5480T	Tx1550nm, Rx1490nm, 2.5Gbps, 80km, Bi-Directional SFP Transceiver with Single LC Receptacle, -40°C ~ +85°C, With DDM.

References

1. Small Form Factor Pluggable (SFP) Transceiver Multi-Source Agreement (MSA), September 2000.
2. Telcordia GR-253-CORE Specifications.
3. "Diagnostic Monitoring Interface for Optical Transceivers" SFF-8472, Rev 10.2, June 1, 2007.

Important Notice

Performance figures, data, and any illustrative material provided in this datasheet are typical and must be specifically confirmed in writing by JHLINK before they become applicable to any particular order or contract. In accordance with the JHLINK policy of continuous improvement, specifications may change without notice. The publication of information in this datasheet does not imply freedom from patent or other protective rights of JHLINK or others. Further details are available from any JHLINK sales representative.

Contact Information

SHENZHEN JUHAIDA INDUSTRIAL DEPLOYMENT CO., LTD.

ADD:HAIHONG INDUSTRIAL PARK,XIXIANGSTREET, BAO'ANDISTRICT,SHENZHEN,CHINA EMAIL:

rainyu77777@gmail.com

WhatsApp:+86 18805172117